

Please read the instructions before starting any work!

# Operating Manual



**Fan series: AAGM**  
**AAGM01**

**POLLRICHDLK®**  
**FAN FACTORIES**

Pollrich DLK Fan Factories  
Pollrich Ventilatoren GmbH  
Neusser Straße 172  
41065 Mönchengladbach  
Telephone: +49 (0) 2161 / 968-0  
Fax: +49 (0) 2161 / 968-307  
email: [info@pollrichdlk.com](mailto:info@pollrichdlk.com)

Web: [www.pollrichdlk.com](http://www.pollrichdlk.com)

DLK Ventilatoren GmbH  
Ziegeleistraße 18  
74214 Schöntal-Berlichingen  
Telephone: +49 (0) 7943 / 9102-0  
Fax: +49 (0) 7943 / 9102-10  
email: [info@pollrichdlk.com](mailto:info@pollrichdlk.com)  
Web: [www.pollrichdlk.com](http://www.pollrichdlk.com)

AAGM, 1, en\_GB

The version supplied may differ from the illustrations in the operating instruction

These instructions were compiled by:

Pollrich DLK Fan Factories

© Pollrich DLK Fan Factories 2013

**Table of contents**

<b>1</b>	<b>General.....</b>	<b>5</b>
1.1	Information about this manual.....	5
1.2	Other valid documents.....	5
1.3	Explanation of symbols.....	5
1.4	Copyright protection.....	6
1.5	Other matters.....	6
1.6	Customer service.....	7
1.7	Declaration of conformity as per EC Machinery Directive 2006/42/EC.....	7
<b>2</b>	<b>Safety.....</b>	<b>9</b>
2.1	Regulations.....	9
2.2	Intendend use.....	9
2.2.1	Vacuum and pressure side flow losses.....	10
2.3	Operator's responsibility.....	10
2.4	Staff requirements.....	11
2.5	Unauthorised persons.....	11
2.6	Mechanical dangers.....	12
2.7	Danger due to electrical currents!.....	13
2.8	Safety equipment.....	13
2.8.1	Securing against switch-on.....	15
2.9	Unauthorised conversions.....	15
<b>3</b>	<b>Technical Data.....</b>	<b>17</b>
<b>4</b>	<b>Setup and Function.....</b>	<b>21</b>
4.1	Working and danger areas.....	21
4.2	Operating elements.....	21
4.3	Brief despriction.....	21
4.3.1	Smoke and heat extraction device.....	21
4.3.2	Device with double function.....	21
4.4	Accessories.....	22
4.4.1	Description of the components.....	22
<b>5</b>	<b>Transportation, packaging and storage.....</b>	<b>23</b>
5.1	Scope of delivery.....	23
5.2	Transport inspection.....	23
5.3	Packaging.....	23
5.4	Safety information.....	24
5.5	Transport.....	25
5.6	Storage.....	27
<b>6</b>	<b>Installation and initial commissioning.....</b>	<b>29</b>
6.1	Safety.....	29
6.2	Assembly.....	30
6.2.1	Fixing the Fan.....	31
6.3	Tests before initialisation.....	33

## Table of contents

6.4	Initialisation.....	33
6.5	Tests after initialisation.....	34
6.6	Converter operation.....	34
<b>7</b>	<b>Operation.....</b>	<b>35</b>
7.1	Safety.....	35
7.2	Targeted stoppage.....	35
7.3	Stoppage in case of an emergency.....	36
<b>8</b>	<b>Maintenance and repair.....</b>	<b>37</b>
8.1	Safety.....	37
8.2	Maintenance of impeller and housing.....	38
8.2.1	Impeller disassembling of Impellers with screwed fixing.....	38
8.2.2	Impeller disassembling of Impellers with Taper-Lock-system.....	40
8.3	Measures after maintenance.....	41
8.4	Replacing the motor.....	42
8.5	Repair.....	42
8.6	Spare parts.....	45
<b>9</b>	<b>Faults.....</b>	<b>47</b>
9.1	Safety.....	47
9.2	Faults table.....	49
<b>10</b>	<b>Disassembly and disposal.....</b>	<b>51</b>
10.1	Safety.....	51
10.2	Dismantling and disposal.....	51
<b>11</b>	<b>Appendix .....</b>	<b>53</b>

# 1 General

## 1.1 Information about this manual

- The operating manual must be kept in the near vicinity of the machine, accessible at all times.
- This manual must be carefully read before beginning any work.
- Keep all the safety information and working instructions.
- Note the local accident prevention regulations and general safety terms.
- Illustrations in this manual may differ from the actual design.
- Note the co-applicable manuals of any installed components.

## 1.2 Other valid documents

### Construction drawing

Construction drawing with following details:

- Order number: Refer to order confirmation
- Fan type: AAGM

## 1.3 Explanation of symbols

### Safety information

- Safety information is identified in this manual with symbols.
- In order to prevent accidents, personal and property damages, it is compulsory to comply with the safety information.
- The operator bears sole responsibility as the person responsible for the product.



#### **WARNING!**

Note to a possible dangerous situation which may lead to death or major injuries.



#### **CAUTION!**

Note to a possible dangerous situation which may lead to minor or light injuries.



#### **NOTICE!**

Note to a possible dangerous situation which may lead to property or environmental damages.

## General

### Tips and recommendations



*Useful tips and recommendations as well as information for efficient and fault-free operation.*

### Specific safety information

The symbols below are used in safety guidelines to indicate specific dangers.



#### **DANGER!**

Note to dangers due to electrical currents. There is the danger of death or major injuries in the case of non-compliance.

### Signs in this manual

In order to identify working instructions, results descriptions, lists, references and other elements, the following signs and marks are used:

- ➔ Identifies step-by-step working instructions.
  - ⇒ Identifies a status or automatic sequence as a result of an action.
- Identifies lists and list entries without a specific order.
- ↪ Identifies references to chapters of this manual.

## 1.4 Copyright protection

This manual is copyright protected and exclusively determined for internal purposes.

Transfer of the manual to third parties, reproductions of any type or form – including in extracts – as well as utilisation and/or notification of the contents are not permitted without the written authorisation of the manufacturer, apart from for internal purposes.

Breaches are subject to damage compensation. Further claims are reserved.

## 1.5 Other matters

All details and information in this manual have been compiled under consideration of the valid norms and regulations, the state of the technology and our years of knowledge and experience.

The actual scope of supply may differ from the explanations and presentations described here in the case of special designs, use of additional order options or due to the latest technical modifications.

The obligations agreed in the supply contract and the general terms of business as well as the manufacturer's terms of delivery and valid regulations at the time of concluding the contract are applicable.

See the general terms of business for all other products.

## **1.6 Customer service**

If there are any questions about commissioning, maintenance, spare parts or something else, please always contact the service of PollrichDLK:



Pollrich Ventilatoren GmbH / Hotline: +49(0) 2161-968-184 /  
Telefax: +49(0) 2161/968-305

DLK Ventilatoren GmbH / Hotline: +49 (0) 7943 - 9102-31 /  
Telefax: +49(0) 7943/9102-10

[www.pollrichdlk.com](http://www.pollrichdlk.com)

## **1.7 Declaration of conformity as per EC Machinery Directive 2006/42/EC**

## General

**POLLRICHDLK®**  
**FAN FACTORIES**

---

### EC – Declaration of Conformity

According to the EC-directive 2006/42/EC

The manufacturer DLK Ventilatoren GmbH  
Ziegeleistraße 18  
D-74214 Schöntal-Berlichingen

herewith declares, that the subsequent product is designed, produced and introduced in conformance to the directive mentioned above.

Description: **Axial fan with direct drive in line fitted**

Type: **AAGM01**

Order number: See name plate

Year of construction: See name plate

Directive: **EC - Machinery Directive 2006/42/EC**

Applied, harmonised standards: DIN EN ISO 12100

DIN EN ISO 13857

DIN EN 60204-1

Berlichingen, 07.01.2013



---

i.A. Dipl.-Ing. Fabian Korn  
CE-Dokumentation Manager  
Research & Development



---

i.V. Dr.-Ing. Daniel Wolfram  
Technical Director  
Research & Development



## 2 Safety

The operator bears sole responsibility for optimal and full personnel protection as well as for safety and fault-free operation.

Failure to comply with the working instructions and safety information provided in this manual can lead to considerable dangers.

### 2.1 Regulations

- All safety and accident prevention regulations are to be observed as well as the machinery directive 2006/42/EC.
- The operator is legally responsible for the product.
- Fans only operate when in perfect condition.

### 2.2 Intended use

The machine is exclusively designed and constructed for the intended use described here.

The AAGM type fan is exclusively intended to transport the mediums stated in chapter 3 on "technical data" within the performance limits and the stated operating conditions.

All details in this manual must be observed.

Any different type of use is misuse.

Any types of claims due to damages caused by misuse are excluded.



#### **WARNING!**

#### **Danger due to misuse!**

- No transport of unsuitable mediums.
- Not operate beyond the specified performance limits (speed maximum, temperature).
- No operation without protective equipment.
- Comply the specific cleaning intervals.
- No operation despite insufficient lubrication.

- Only explosion protected fans mounted in areas at risk of explosion.
- Set cleaning intervals in dusty areas.
- For standard designs, the place of installation may not be higher than 1000 m above sea level.
- Assembly and connection must take place in accordance with this manual.
- The fan only use in perfect technical condition.

## Safety

- All unintended uses are prohibited.
- This manual must be handed over to the operator after initialisation.

*“Further information can be requested from the manufacturer”*

### 2.2.1 Vacuum and pressure side flow losses



#### **NOTICE!**

The flow behaviour of a fan can be negatively influenced by unfavourable installation conditions. The operating point of the fan can move to an unauthorised working range (splitting range). In this case, there is no claim to a guarantee for consequential damages, especially due to (resonance) vibrations.

## 2.3 Operator's responsibility

### Operator

The operator is the person who operates the machine for commercial or business purposes by himself, or who hands the machine over to third parties for use/application and who bears legal product responsibility during operation for the protection of users, personnel or third parties.

### Operator's duties

The machine is deployed in commercial areas. The operator of the machine is therefore subject to the legal obligations and notification obligations on work safety.

Alongside the safety information in this manual, the valid safety, accident prevention and environmental protection regulations must be complied with for the machine's area of use.

The following particularly applies:

- The operator must inform himself about the valid work protection and determine additional dangers in a danger analysis caused by special working conditions where the machine is used. These must be implemented for operation of the machine in the form of operating instructions.
- The operator must check whether the operating instructions he has produced for the machine correspond with the current status of rules throughout the operating period and adapt them if necessary.
- The operator must ensure that all employees who work with the machine have read and understood this manual. Furthermore, he must train employees at regular intervals and inform about the dangers.

- The operator must regularly instruct the members of staff according to his safety-documents.
- The operator must provide members of staff with the necessary protective equipment.

In addition, the operator is responsible that the machine is always being kept in perfect technical condition. The following therefor applies:

- The operator must ensure that the maintenance intervals described in this manual are complied with.
- The operator must allow all safety equipment to be regularly checked for functionality and completeness.
- The general building approval is enclosed upon delivery.

### 2.4 Staff requirements



**WARNING!**

**Danger of major injuries or considerable damage to property if members of personnel have insufficient qualifications!**

- Only allow all work to be performed by qualified personnel.
- Keep unqualified personnel away from danger areas.

### 2.5 Unauthorised persons



**WARNING!**

**Danger of death to unauthorised persons in the danger and working area!**

- Keep unauthorised persons away from the danger and working area.
- In case of any doubt, address the person involved and send them out of the danger and working area.
- Interrupt work as long as unauthorised persons are inside the danger and working area.

# Safety

## 2.6 Mechanical dangers

### Fan

**WARNING!****Danger of injury due to rotating parts!**

- During operation, do not reach into the moving wheel or tamper with the wheel.
- Do not open covers and maintenance covers during operation.
- Make sure that the wheel is not accessible during operation.
- Pay attention to the after-run time: make sure that no more components are moving before opening the covers for maintenance purposes.
- Switch off the fan before beginning any work on moving components and secure it against being switched back on. Make sure that all components have come to a standstill.
- This fan fulfills the requirements of EC-machinery directive 2006/42/EC, when one of the following requirements are secured:
  - The fan is attached at pressure and suction side.
  - The fan is attached at pressure side and equipped with safety devices (f.e. safety wire) at suction side.
  - The fan is attached at suction side and equipped with safety devices (f.e. safety wire) at pressure side.
  - The fan is equipped at pressure and suction side with safety devices (f.e. safety wire) at pressure side..

### Vibrations

**WARNING!****Danger of injury caused by heavy vibrations!**

- Do not take the vibration dampers out of operation.
- Do not remain within the vibrating area during operation.

### Sharp edges and pointed corners

**CAUTION!****Danger of injury due to sharp edges and pointed corners!**

- Proceed carefully when working near to sharp edges and pointed corners.
- Wear protective gloves in case of any doubt.

## 2.7 Danger due to electrical currents!

### Electrical current



#### **DANGER!**

##### **Danger of death due to electrical currents!**

- Work on the electrical system may only be performed by an electrician.
- Shutdown the voltage supply immediately and arrange repair in case of any damages to the insulation.
- Make sure that the electrical system and equipment is disconnected before beginning any work on the live parts and ensure this status for the full period of work. Observe the 5 safety regulations:
  - Disconnect
  - Secure against being switched back on
  - Ensure the absence of voltage
  - Earth and short-circuit
  - Cover or limit neighbouring live parts
- Never bridge fuses or take them out of operation. Comply with the correct fuse rating when replacing fuses.
- Keep moisture away from live parts. This can lead to short-circuit.

## 2.8 Safety equipment



#### **WARNING!**

##### **Danger of life caused by safety equipment, which are out of commission**

- Check whether all safety equipment is functional and correctly installed before beginning any work.
- Never take safety equipment out of operation or bridge it.
- Make sure that all safety equipment is always accessible.
- The safety equipment has to be evaluated by taking the safety concept of the complete construction into account.

### Safety equipment

## Safety

### Safety helmet



Safety helmet serve the purpose of protecting against falling objects.

### Ear protectors



Ear protectors serve the purpose of protection against damage to hearing.

### Protective work clothing



Protective work clothing is closely fitting work clothes with low tensile strength, with close fitting sleeves and without protruding parts. It generally serves the purpose of preventing clothes being caught in moving machine parts. Do not wear any rings, chains or other jewelery.

### Protective gloves



Protective gloves serve the purpose of providing protection to hands against friction, scrapes, punctures or deeper injuries as well as against contact with hot surfaces.

### Safety footwear



Safety footwear serves the purpose of protecting against heavy falling parts and slipping on slippery surfaces.

### Hairnet



The hairnet is a special protective measure for long hair, generally used to prevent hair being caught by moving machine parts.

### 2.8.1 Securing against switch-on



**WARNING!**

**Danger of life caused by unauthorised or uncontrolled switch-on!**

- Before securing against being switched back on, make sure that all safety equipment is mounted and functional and that there are no dangers caused to other persons.
- Always make sure that the sequence described as followed for securing against switch-on is complied with.

#### Secure against switch-on

1. ➤ Switch off the energy supply
2. ➤ Inform responsible persons about work in the danger area
3. ➤ Provide the machine and controls with a sign referring to work in the danger area and prohibiting switch-on. Provide the sign with the following details:
  - Switched off on:: ..... at: ..... by: .....
  - Note: do not switch on!
4. ➤ After all work has been performed; make sure that there are no dangers to persons.
5. ➤ Make sure that all safety and protection equipment is installed and functional.
6. ➤ Remove the sign.

### 2.9 Unauthorised conversions

Conversions and changes to the fan are not permitted.

## **Safety**



### **3 Technical Data**

Refer to type label for the fan operating data, for further technical data refer to PollrichDLK order confirmation.

# Technical Data

## Product data sheet AAGM01 (ToromaxPro duplex by Pollrich DLK)



Medium pressure axial fan, direct driven in car park execution. Suitable for ventilation up to 40 °C constant temperature.

**Consisting of:**

Consisting of two fans fitted in line with guide vanes  
Casing of sheet-steel with rolled flanges on both sides and with welded motor casing incl. downstream guide vanes. Connected by casing of sheet-steel. Optimal surface protection by powder coating RAL 7015.

Impellers with corrosion-resistant hub and easy-to-assemble shaft / hub connection. Infinitely adjustable when at rest, aerofoil section blades made of tensile aluminum cast alloy.  
Dynamically balanced according to DIN ISO 1940-1, balance quality G 6.3 < 4.0 mm/s for flexible subassembly.

**Three-phase alternating current motors** / IEC - standard motor up to size 132 type B14, bigger sizes in type B5, protection type IP 55 / insulation class F. Motor power selected for cold start-up at 20 °C.

PVC control line, radially designed.  
Electrical wiring at clamping boxes at the outside (optional accessory).

**Accuracy class** 2 acc. to DIN 24 166

**Tolerances** acc. to DIN 2768

**Performance tests** acc. to ISO 5801

**Fan size range:**  
DN 315 - DN 1120

**Application:**  
For ventilation up to max. 40 °C constant temperature

**Technical data:** (50Hz)

$q_v = 1.000 - 130.000 \text{ m}^3/\text{h}$

$P_r = 100 - 4.500 \text{ Pa}$

$P_e = 0.55 - 45 \text{ kW}$  (each motor)

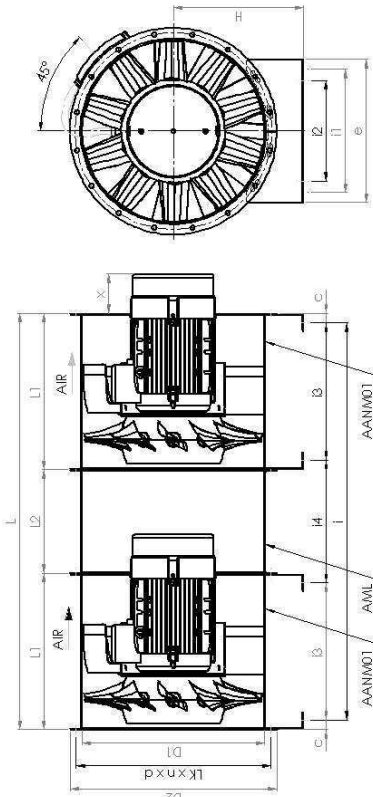

**POLLRICHDLK®**  
**FAN FACTORIES**

Installation on rubber-anti-vibration mounts

DN	ø315	ø355	ø400	ø450	ø500	ø560	ø710	ø800	ø900	ø1000	ø1120
D1	317	357	402	452	502	562	713	804	905	1005	1128
D2	380	415	465	515	565	640	710	810	1000	1100	1216
LK x n	356 x 8	395 x 12	438 x 12	487 x 12	541 x 16	605 x 16	674 x 16	837 x 16	934 x 24	1043 x 24	1175 x 20
x d	ø9.5	ø9.5	ø9.5	ø9.5	ø9.5	ø11.5	ø11.5	ø11.5	ø11.5	ø11.5	ø11.5
L	766	808	808	1008	1008	1230	1480	1560	1800	1800	2160
L1	240	303	303	378	378	480	555	585	675	675	810
L2	160	202	202	252	252	320	370	390	450	450	540
H	230	261	284	309	334	400	435	495	540	590	706
e	293	317	351	395	438	440	526	688	760	840	930
i	586	754	754	953	953	1225	1424	1409	1487	1727	2034
l	250	270	300	324	360	380	462	546	610	660	730
l2						370	426	400	500	500	500
l3	186	249	249	323	323	425	499	484	512	602	702
l4	214	256	256	307	307	375	426	441	463	523	630
c	27	27	27	27.5	27.5	27.5	28	35.5	36.5	36.5	45
Motor size	71	71	71	71	80	90	100	100	132	132	132
weight in kg	47	57	70	81	95	122	155	246	353	443	672
	60	97	101	139	229	250	284	479	682	865	1115

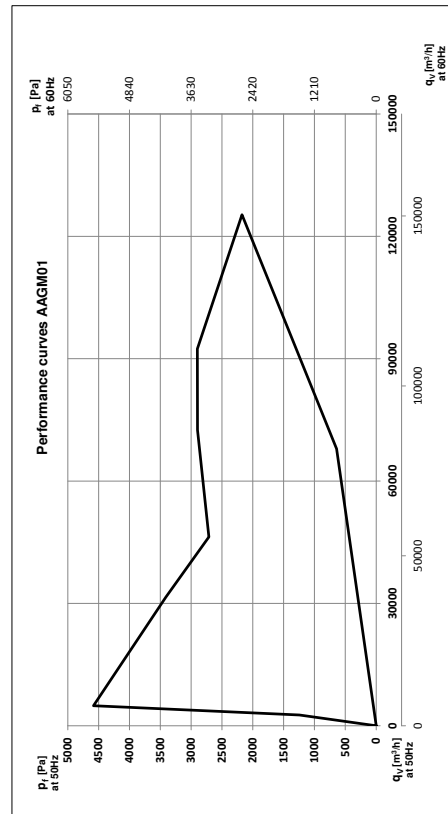

Dimensions and design subject to alteration  
\* fan incl. Motor weight (depending on motor size)  
all dimensions in mm

DLK Ventilatoren GmbH  
D-74214 Schöndal-Berlichingen  
Telefon: +49(0) 7943 / 9102-0  
Telefax: +49(0) 7943 / 9102-10  
e-mail: info@pollrichdlk.com  
Internet: http://www.pollrichdlk.com

2013-03-05

**Product data sheet AAGM01 (ToromaxPro duplex by Pollrich DLK)**



**Series AANM01**  
Medium pressure axial fan,  
direct driven in car park execution

**Fan size range:**  
DN 1250 - DN 1600

**Application:**  
For ventilation up to max. 40°C  
constant temperature

**Technical data:** (50Hz)  
 $Q_v =$  up to 170.000 m³/h  
 $p_r =$  up to 5000 Pa  
 $P_e =$  15 – 90 kW (each motor)

**Medium pressure axial fan, direct driven in car park execution. Suitable for ventilation up to 40 °C constant temperature.**

**Consisting of:**  
Casing of sheet steel with rolled flanges on both sides and with welded motor casing incl. downstream guide vanes. Optimal surface protection by powder coating RAL 7015.

**Impeller** with corrosion-resistant hub and easy-to-assemble shaft / hub connection with taper lock bush. Infinitely adjustable when at rest, aerofoil section blades made of high-strength hollow profiled blades of sheet steel With rotary hub covering Dynamically balanced according to DIN ISO 1940-1, balance quality G 6.3 < 4,0 mm/s for flexible subassembly .

Three-phase alternating current motor / IEC - standard motor in B5 mounting, protection type IP 55 / insulation class F or H, Motor power selected for cold start-up at 20°C. PVC control line, radially designed. Electrical wiring at clamping box at the outside.

**Accuracy class 2** acc. to DIN 24 166  
**Tolerances** acc. to DIN 2768  
**Performance tests** acc. to ISO 5801

**POLLRICHDLK®**  
FAN FACTORIES

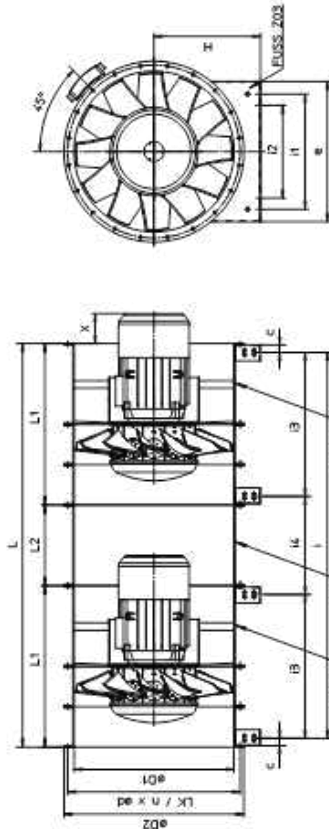

Montage auf Gummischwingsdämpfern

Fan size	ø1250	ø1400	ø1600
D1	1258	1410	1610
D2	1360	1520	1732
Lk x n x d	1311 x 20 x ø14	1469 x 24 x ø14	165 x 24 x ø14
L	2690	3330	4000
L1	1080	1330	1600
L2	540	670	800
H	733	900	1000
e	986	1008	1100
i	2690	3320	3988
i1	786	768	818
i2	500	-----	-----
i3	980	1230	1478
i4	640	770	992
c	45	45	55
<b>Motor size weight in kg</b>	200-280 800 - 1250	225-280 900 - 1250	225-280 950 - 1250

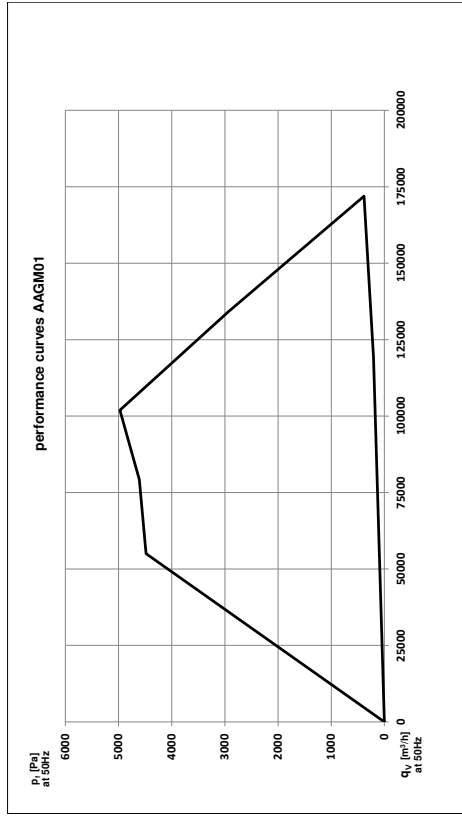

**Dimensions and design subject to alteration**  
 \* fan incl. Motor weight (depending on motor size)  
 all dimensions in mm

DLK Ventilatoren GmbH  
 D-74214 Schönlai-Berchingen  
 Telefon: +49(0) 7943 / 9102-0  
 Telefax: +49(0) 79 43 / 9102-10  
 e-mail: info@pollrichdlk.com  
 Internet: http://www.pollrichdlk.com

2013-03-05

## Technical Data

### 4 Setup and Function

#### 4.1 Working and danger areas

No permanent working areas are sheduled in the area of the fan.

#### 4.2 Operating elements



*Operation of the fan takes place using the controls provided on-site.*

*Information on operation can be taken from the corresponding operating manual.*

#### 4.3 Brief despcription

##### 4.3.1 Smoke and heat extraction device

Device is not suitable for extraction of smoke and hot gases from a building in case of fire.

##### 4.3.2 Device with double function

Device is no smoke and heat extraction device that may be used for daily ventilation

## Setup and Function

### 4.4 Accessories

#### 4.4.1 Description of the components

- Mounting feet for floor or ceiling installation
- Inlet nozzle with or without wire guard to prevent air turbulence and to reduce the sound level
- Wire guard for securing the safety regulations
- Counter flange round, pressed as an angle flange for connection of casings
- Casing long for tube extension
- self-activating sealing flap prevents the penetration of parts and protects against external weather
- Compensator (round), for balancing of movements
- Rubber anti vibration mounts to reduce oscillation
- Terminal box of aluminium or plastic
- Repair switch for electrical protection for repair or maintenance on the device
- Cylindrical silencer with or without core for noise reduction
- Feet for cylindrical silencer

## Transportation, packaging and storage

### 5 Transportation, packaging and storage

#### 5.1 Scope of delivery



*A list of of supplied components is contained in the accompanying documents.*

#### 5.2 Transport inspection

Immediately check the delivery upon receipt for completeness, technical changes and transport damages.

Proceed as follows if any external transport damages or technical changes can be identified:

- Do not accept the delivery or only subject to conditions
- Note the extent of damage on the transport documents or on the shipper's delivery note
- Initiate the complaint process.



*Make a complaint about any defects as soon as they are recognised. Claims for replacement of damages can only be enforced within the valid complaints period.*

#### 5.3 Packaging

##### For packaging

Packaging is according to the expected transport conditions.

The packaging should protect the individual components against transport damages, corrosion and other damages up to the point of assembly. Therefore do not destroy the packaging and only remove it shortly before assembly.

##### Symbols on the packaging

Always pay attention to following symbols:

##### This way up



The points of the arrows identify the top of the packing item. They must always point upwards otherwise the contents could become damaged

## Transportation, packaging and storage

### Fragile



Identifies a package with fragile or susceptible contents.  
Handle the packing item with care, do not let it fall and do not subject it to impacts.

### Protect against moisture



Protect the packing item against moisture and keep them dry.

### Attach here



Only apply attachments (attachment chains, lifting straps) at points marked with this symbol..

### Centre of gravity



identifies the centre of gravity of the packing item.  
Pay attention to the position of the centre of gravity when lifting and transporting.

### Temperature range



Only transport and store the packing item within the specified temperature range.

## 5.4 Safety information

### Suspended loads



#### **WARNING!**

#### **Danger of death due to suspended loads!**

- Always cordon off the transport area according to the local regulations
- Never step below or into the movement range of suspended loads
- Only move loads under supervision
- Only use authorised lifting equipment and attachments with sufficient load-bearing capacity
- Lifting equipment such as ropes and straps may not be played against sharp edges and corners - do not knot or twist
- Lower the load when leaving the work station



## Transportation, packaging and storage

### Off-centre centres of gravity



**WARNING!**

**Danger of injury due to falling or tipping package!**

- Only use the attachment points, which are approved from the manufacturer.
- Generally contact the manufacturer in case of any uncertainty.

### Transport loops



**WARNING!**

**Danger of injury due to use of incorrect transport loops!**

- Only use transport loops marked by the manufacturer for the whole packing item.
- Generally contact the manufacturer in case of any uncertainty.

### Swinging transport item



**WARNING!**

**Danger of injury due to swinging transport item!**

- Make sure that no persons, objects or obstacles are within the swinging range of the transport item during transport.

### Incorrect transport



**NOTICE!**

**Damage to property due to incorrect transport!**

- When unloading transport items upon delivery or transporting internally, proceed with caution and observe the symbols and information on the packaging.
- Only use the attachment points provided.
- Transport fans avoiding impacts and jerking.

## 5.5 Transport

### Attachment points



**NOTICE!**

The transport loops on the motor, bearing or housing are only intended to take the weight of the respective machine parts.

## Transportation, packaging and storage



Fig. 1: Attachment point



Attachment points for transport are marked as shown in .

The position of the attachment points is orientated towards the size of the fan and the individual transport conditions.

Please contact the manufacturer in case of any uncertainty.

### Transporting transport items with a crane

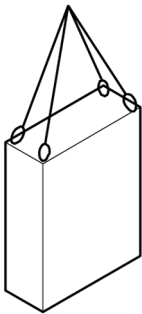

Fig. 2: Attaching transport items

Transport items which have transport loops can be directly transported with your own crane:

1. ➤ Attach ropes, straps or multi-point suspensions accordingly. anschlagen.



#### CAUTION!

Do not damage the surface protection when hooking and transporting.

2. ➤ Make sure that transport item is hanging straight; pay attention to an off-centre centre of gravity if applicable.
3. ➤ Begin transport.

### Transporting pallets with a crane

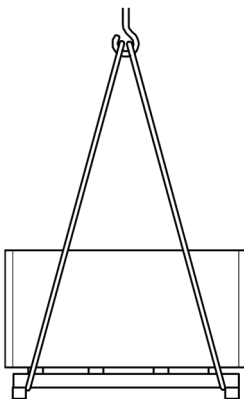

Fig. 3: Attaching pallets

Transport items that are fixed on pallets can be transported with a suitable crane:

Protective equipment: ■ Hard hat

1. ➤ Attach ropes, straps or multi-point suspensions to pallet accordingly and secure the pallet against slipping.
2. ➤ Check whether the transport items are not damaged by the attachment equipment. Use of the attachment equipment is necessary.
3. ➤ Ensure that pallets with an off-centre centre of gravity cannot tilt.
4. ➤ Begin transport.

### Transporting pallets with a forklift truck

Transport items that are fixed on pallets can be transported with a suitable forklift truck:

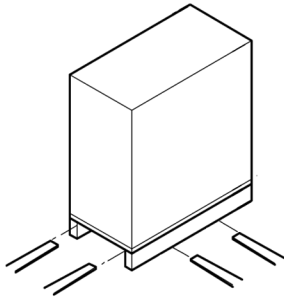

Fig. 4: transport with a forklift truck

## Transportation, packaging and storage

1. → Drive the forks on the forklift truck between or beneath the bars on the pallet.
2. → Drive the forks in far enough so that they protrude on the other side.
3. → Ensure that pallets with an off-centre centre of gravity cannot tilt.
4. → Lift the pallet with the transport item and begin transportation.

### 5.6 Storage

Store PollrichDLK fans in the original packaging up until installation (film packaging without tightening straps) according to the symbols of the package.

#### Longer periods of intermediate storage

#### Impeller

Turn by hand once a month (1-2 turns). Carefully turn the impeller.



**WARNING!**  
**Danger of injury due to rotating parts!**  
refer to chapter .

#### Motor

When stored separately, turn by hand once a month (1-2 turns). Pay attention to the motor operating manual!

#### Place of storage

In a closed, dry room. Maximum standstill period: 6 months.

## **Transportation, packaging and storage**

## Installation and initial commissioning

### 6 Installation and initial commissioning

Refer to declaration of incorporation or declaration of conformity in accordance with the machinery directive 2006/42/EC.



*Initialisation is to be recorded.*

*Immediately stop the machine if values are identified beyond the performance limits and contact the manufacturer.*

*More commissioning have to be execute according to the initialisation.*

#### 6.1 Safety

##### Screw torques

The torque levels in accordance of VDI 2230 Oct- 2001 (acc. Appendix).



##### **WARNING!**

##### **Danger of injury due to incorrect screw torques!**

- Always comply with the torque specifications.
- Never exceed the maximum authorised screw torque.
- Regularly check the screw torque levels.
- Always observe the relevant directives and design criteria for screw connections.

##### Securing against switch-on



##### **WARNING!**

##### **Danger of death due to unauthorised switch-on!**

Refer to ↪ Chapter 2.8.1 “Securing against switch-on” on page 15.

## Installation and initial commissioning

### Incorrect installation and initialisation



#### **WARNING!**

#### **Danger of injury due to incorrect installation and initialisation!**

- Ensure that there is sufficient space for assembly before beginning any work.
- Handle open, sharp edged components with care.
- Pay attention to tidiness and cleanliness in the place of assembly! Loosely positioned components or those left lying around are potential sources of accidents.
- Mount the components professionally. Comply with the specified screw torque levels.
- Secure components so that they cannot fall down or fall over.
- Pay attention to the following before initialisation:
  - Ensure that all installation work has been implemented and completed in accordance with the details and information in the manual.
  - Ensure that no persons are found within the danger area.

## 6.2 Assembly

### Clearances



*The fan must be mounted so that there is sufficient clearance for maintenance and repair measures.*

### Welding prohibited



#### **NOTICE!**

#### **Danger of device damages due to welding work on the fan!**

- Do not carry out any welding work on the fan.

## Installation and initial commissioning

### 6.2.1 Fixing the Fan

#### Fixing the fan

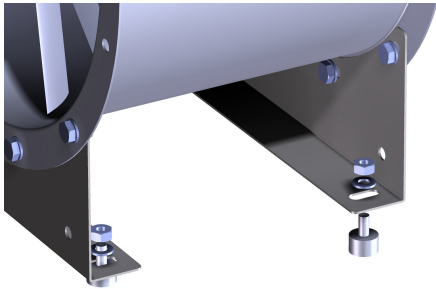
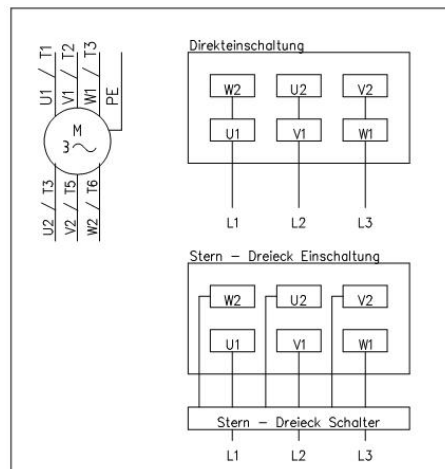
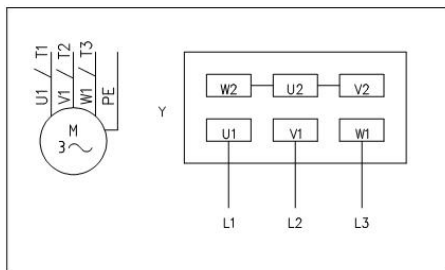

Fig. 5: Fixing the fan

#### wiring diagrams



The mounting holes on the fan or base frame are so arranged that an even load of the bedrock is ensured.

#### Requirements:

- The foundation is prepared..

1. ➔ Align the fan straight with a spirit level and filler plate.
2. ➔ Professionally connect the fan or base frame with the ground using all attachment holes, suitable dowls, screws and heavy-load anchors.
3. ➔ The assembly of the fan must be made with anti vibration mounts so that no transmission of vibrations can be made! See Fig. 5
4. ➔ Check and ensure the screws for a tight fit!

The fan has to be connected by an electrician according to the following wiring diagrams. In other cases the declaration of conformity of chapter 2 loses their validity

#### 1. ➔ D/Y

star connection of three-phase motors 230V/400V at rated voltage 400V

star connection of three-phase motors 400V/690V at rated voltage 690V

#### 2. ➔ D/Y

delta connection of three-phase motors 230V/400V at rated voltage 230V

delta connection of three-phase motors 400V/690V at rated voltage 400V

## Installation and initial commissioning

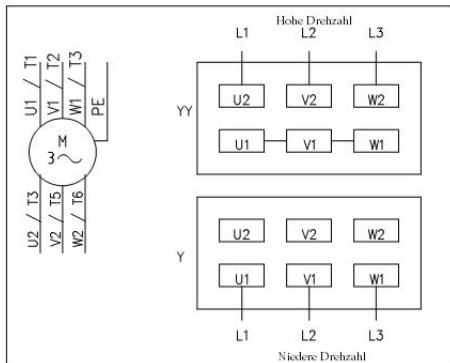

### 3. ➤ YY/YY

Connection for three-phase motors with one winding for 2/4 poles, 4/8 poles, 6/12 poles.

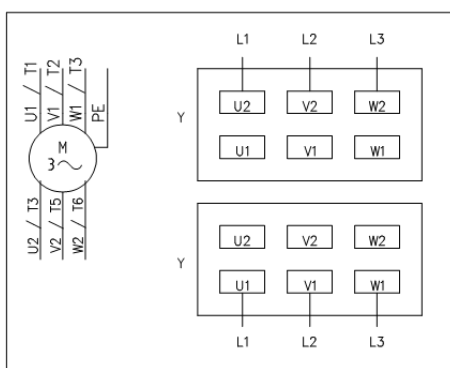

### 4. ➤ Y/Y

Connection for three-phase motors with separate windings for 4/6 poles, 6/8 poles, 8/12 poles.

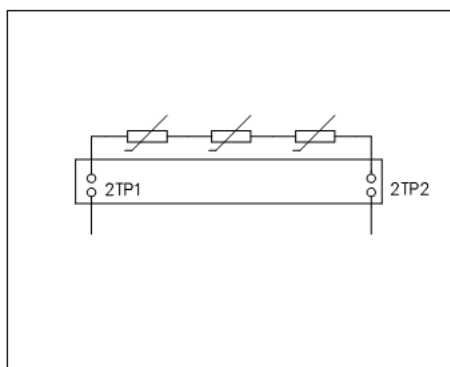

### 5. ➤ Connection of PTC resistor. Maximum voltage is 2,5V.

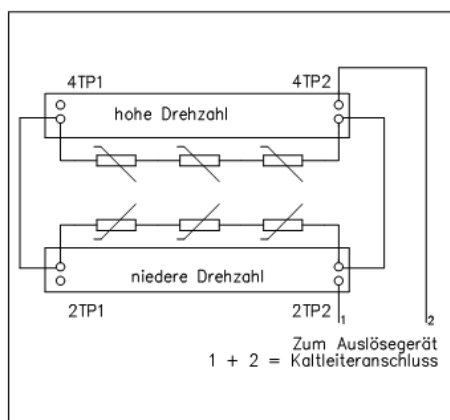

### 6. ➤ Connection of PTC resistor on 2-pole changing motors. Maximum voltage is 2,5V.



## Installation and initial commissioning

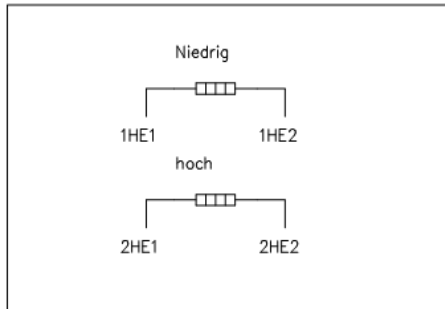

7. ➔ Connection of stationary heating installation. Pay attention to the maximum voltage of the stationary heating.

### 6.3 Tests before initialisation

Prerequisites:

- Assembly of the machine and protective devices has been implemented and concluded.
- The machine is secured against unauthorised switch-on.



**WARNING!**

**Danger of death due to unauthorised switch-on!**

refer to Chapter 2.8.1 “Securing against switch-on” on page 15



**WARNING!**

**Danger of injury due to rotating parts!**

refer to chapter .

1. ➔ Check the free movement of the wheel by turning it by hand
2. ➔ Check the connection of the drive unit and all monitoring equipment with the energy supply (electrician).
3. ➔ Ensure that all transport protection has been removed
4. ➔ Ensure that no tools, small parts or dirt from assembly are found in the fan housing
5. ➔ If ATEX: Check correct earthing. Pay particular attention to correct assembly of the potential compensators and earthing strips on the earthing loop.

### 6.4 Initialisation



*Obtain approval from the system operator before initialisation and record the operating data during initialisation.*

## Installation and initial commissioning

- ➔ Switch on the fan using the controls provided by the operator.



*The bearing temperature may initially increase abnormally during initialisation until the correct amount of grease has automatically set. If the bearing temperature rises above 80°C, switch off the fan, allow the bearings to cool and then switch the fan back on.*

### 6.5 Tests after initialisation

Carry out the following steps after one operating hour after initialisation with the fan on:

1. ➔ Inspect the fan if there are any unusual noises and contact the manufacturer if necessary.
2. ➔ Inspect the fan for vibrations and contact the manufacturer if necessary.

### 6.6 Converter operation

Critical frequencies are to be hidden on the frequency converter.

- Critical frequencies are to be hidden on the frequency converter.
- When using a frequency converter the conformity with EC-directive 2004/108/EC has to be secured
- The frequency converterterter has to be bypassed in case of fire.

## **7 Operation**

### **7.1 Safety**

#### **Incorrect operation**



**WARNING!**

**Danger of injury due to incorrect operation!**

- All operating steps must be carried out in accordance with the details and information in the manual for the controls provided by the operator.
- Before beginning any work, ensure that
  - all covers and safety equipment are installed and in correct working order.
  - no persons are found within the danger area.
- Never disable or bridge safety equipment during operation.

### **7.2 Targeted stoppage**

Carry out the following steps to stop the fan switched on:

- 1.** ➤ Switch off the fan using the controls provided by the operator.
- 2.** ➤ Wait for the after-run period of the wheel to finish.



**WARNING!**

**Danger of injury due to rotating parts!**

refer to chapter .

## Operation

### 7.3 Stoppage in case of an emergency

**Stoppage in case of an emergency** Proceed as follows in case of an emergency:



1. ▶ Trigger the emergency shutdown with the emergency shut-down facility
2. ▶ If there is no danger to your own health, rescue other persons from the danger zone
3. ▶ Initiate first aid measures if necessary
4. ▶ Alarm the Fire Brigade and/or ambulance service
5. ▶ Inform the responsible persons on-site
6. ▶ Switch the machine off and secure it against being switched back on.
7. ▶ Clear the access routes for emergency vehicles
8. ▶ Instruct the drivers of emergency vehicles.
9. ▶ Inform the authorities if necessary due to the severity of the emergency.
10. ▶ Deploy specialist personnel to address the fault

**After the emergency measures**

 **WARNING!**  
**Danger of death due to unauthorised switch-on!**  
refer to chapter ↗ *Chapter 2.8.1 "Securing against switch-on" on page 15.*

11. ▶ Check the machine before reinitialisation and ensure that all safety equipment is installed and fully functional.

### 8 Maintenance and repair

#### 8.1 Safety

##### Electrical system



**DANGER!**

**Danger of death due to electrical current!**

refer to chapter .

##### Securing against switch-on



**WARNING!**

**Danger of death due to unauthorised switch-on!**

refer to ↗ Chapter 2.8.1 “Securing against switch-on”  
on page 15.

##### Poisonous mediums



**WARNING!**

**Danger of damages to health due to residues of  
poisonous mediums in the fan casing!**

- Before working on the interior, make sure that no  
poisonous residues of mediums are inside the fan.

##### acid mediums



**WARNING!**

**Danger of damages to health due to residues of acid  
mediums in the fan casing!**

- Before working on the interior, make sure that no  
poisonous residues of mediums are inside the fan.

##### Moving components



**WARNING!**

**Danger of injury due to moving components!**

Refer to chapter .

## Maintenance and repair

### Explosion protection



**WARNING!**

**Explosion protection!**

Inserting of ignition sources like sparks, open flames or hot surfaces may cause an explosion in an Ex-Zone.

- Before working in an Ex-Zone, obtain working-clearance.
- Working exclusive without explosive atmosphere.
- Use Tools which have clearance for Ex-Zone.

The Non-attention of these advices leads to loosing the explosion protection.

### Incorrectly implemented maintenance work



**WARNING!**

**Danger of injury due to incorrectly implemented maintenance work!**

- Ensure that there is sufficient space for assembly before beginning any work
- Pay attention to tidiness and cleanliness in the place of assembly! Loosely positioned components or those left lying around are potential sources of accidents
- When components have been removed, pay attention to correct assembly, reinstall all fixing elements and comply with the screw torque levels
- Pay attention to the following before initialisation:
  - Ensure that all maintenance work has been implemented and completed in accordance with the details and information in the manual
  - Ensure that no persons are within the danger area
  - Ensure that all covers and safety equipment is installed and in perfect working order

### Environmental protection

The following information on environmental protection must be observed during maintenance work:

- Remove any escaping, used or excess grease, from all lubrication points that are supplied with a lubricant, by hand and dispose of it in accordance with the valid local regulations.
- Collect any replaced oils in suitable containers and dispose of it in accordance with the valid local regulations.

## 8.2 Maintenance of impeller and housing

### 8.2.1 Impeller disassembly of Impellers with screwed fixing

#### a) Impeller dismantling

## Maintenance and repair



### CAUTION!

*“- Switch the fan tension-free.”*

*“- Wait for the standstill of the impeller.”*

*“- Ensure the fan against unauthorised switch-on!”*

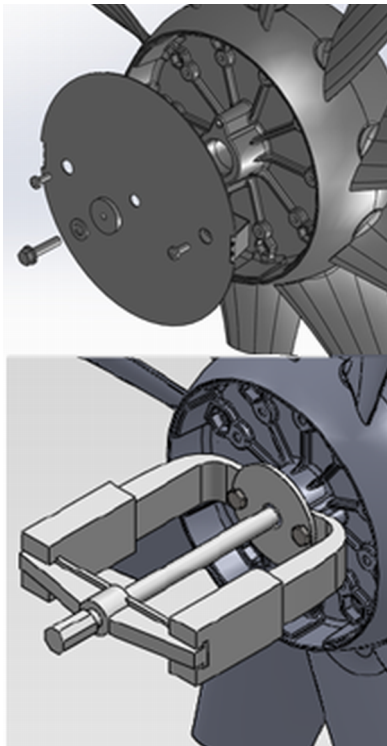

1. ➤ Remove self-cutting screws which fix the hub casing.
2. ➤ Loose axial fixing of the hub on the shaft. Therefore remove the screw which connects the motor hub with the impeller.
3. ➤ To attach the pull-off device, two M8 tapped hole have to be inserted.
4. ➤ Fix a pull-off plate with two M8-screws on the impeller hub.
5. ➤ Remove the impeller with help of a pull-off device..

### b) Blade angle

The blade angle is only to be changed by the manufacturer.

### c) Mounting the impeller



### CAUTION!

*“- Switch the fan tension-free and ensure the fan against unauthorised switch-on!”*

1. ➤ Note the direction of running and rotation. (refer to the type label).
2. ➤ Insert impeller. If not possible heat the impeller hub.
3. ➤ Fix hub casing with self cutting screws.
4. ➤ Screw together the impeller with the hex head screws, front disk, tooth washer and washer.

## Maintenance and repair

### Tightening torque of the screws:

The tightening torques based on the calculation base of VDI 2230 Okt-2001 (see appendix).

The impeller must not grind on the housing while rotating the impeller by hand (in the direction of rotation). **Carry out a check and test run before re-commissioning.**

### 8.2.2 Impeller disassembling of Impellers with Taper-Lock-system

#### a) Impeller disassembling



#### CAUTION!

- Switch the fan tension-free.
- Wait for the standstill of the impeller.
- Ensure the fan against unauthorised switch-on!

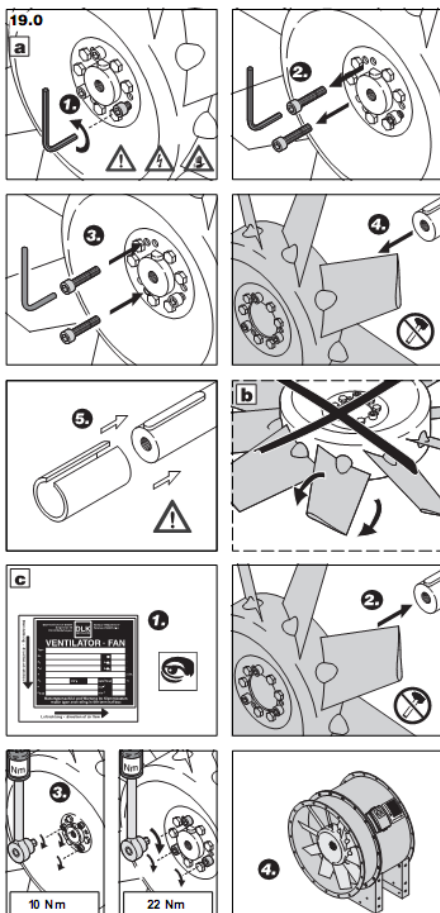

1. ➤ Remove cover of Impeller-hub cover.
2. ➤ Remove both hexagonal screws.
3. ➤ Turn one hexagonal screw to create the dismantling thread.
4. ➤ Remove the impeller.

#### b) Blade angle



## Maintenance and repair

The blade angle is only to be changed by the manufacturer.

c) Mounting the impeller



**CAUTION!**

*“- Switch the fan tension-free and ensure the fan against unauthorised switch-on!”*

1. ➤ Insert core of taper-lock-system into the hub.
2. ➤ Turn on both hexagonal screws by hand.
3. ➤ Note the direction of running and rotation. (refer to the type label).
4. ➤ Turn on both hexagonal screws equally, release the impeller.
5. ➤ Insert cover.

**Tightening torque of the screws:**

The tightening torques based on the calculation base of VDI 2230 Okt-2001 (see appendix).

The impeller must not grind on the housing while rotating the impeller by hand (in the direction of rotation). **Carry out a check and test run before re-commissioning**

### 8.3 Measures after maintenance

After ending maintenance work caused by faults, refer to  *Chapter 9.2 “Faults table” on page 49* and repairs and carry out the following steps:

1. ➤ Check and ensure all previously loosened screw connections for a tight fit.
2. ➤ Check whether all previously removed protection equipment and covers are reinstalled correctly.
3. ➤ Make sure that all used tools, materials and other equipment have been removed from the working area.
4. ➤ Clean the working area and remove any escaped substances such as fluids, processing materials or similar.
5. ➤ Make sure that all safety equipment on the machine is in perfect working order.

## Maintenance and repair

### 8.4 Replacing the motor

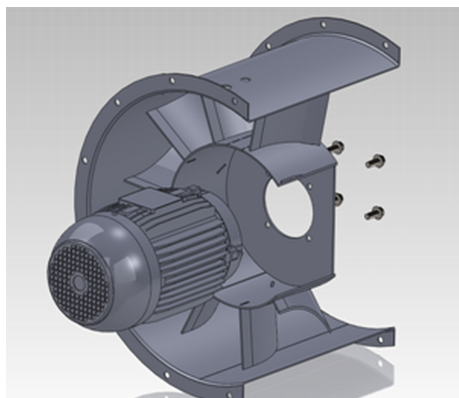

Fig. 6: Replacing the motor (B5)



#### **CAUTION!**

he electrical connection may only be carried out by an electrician in accordance with the electro-technical regulations (VDE). Refer to chapter und ↗ Chapter 8.6 "Spare parts" on page 45

#### **Replacing the motor (see Fig.6)**

- Pay attention to the motor manufacturer's operating manual and comply with all safety regulations!
- Check and ensure the screws for a tight fit!

### 8.5 Repair

## Maintenance and repair

### Factory maintenance intervals



- The function and operational safety of the fan depends on correct controls, maintenance and repairs

- We recommend that the operator notifies the manufacturer's customer service in good time in accordance with the marked test label Fig. 7

Fig. 7: test label

## Maintenance and repair



Fig. 8: Quality label



**CAUTION!**

- Only original spare parts may be installed due to safety reasons!
- Carefully dismantle the fan complying with all safety regulations.



**CAUTION!**

After completing assembly of the impeller, motor and bearings, a vibration test and operational balancing is recommended as required before initialisation (in accordance with "initialisation").

### Maintenance and inspection recommendations

We recommend that you have the fans checked at regular intervals by specialist staff or a specialist company to determine whether they are fully functional and check in what condition they are in. Have this inspection documented.

The type and extent of maintenance and the maintenance intervals always depend on the way in which the fan is used. The following table provides recommendations for these intervals and is based on VDMA 24186-1.

Description	Interval
Test run (20 min)	Every 6 months
Test run (1 h)	Once a year

## Maintenance and repair

Description	Interval
For combustion gas fans: Functional test of the bypass for the frequency converter and all electrical components	Every 6 months
Check the direction of rotation	Every 6 months
Check the flexible connections	Once a year
Check the flywheel for imbalance	Once a year
Check the safety devices to make sure they are functional	Once a year
Re-lubricate the bearing	Once a month
Check the V-belt for damage, check the tension and alignment	Once a year
Check the fan for external signs of damage, soiling, corrosion	Every 6 months
Check the motor for external signs of damage, soiling, corrosion	Every 6 months
Check the motor bearing for noises	Once a year
Check that the connection terminals are firmly in place	Once a year
Check the voltage and current strength	Once a year

### 8.6 Spare parts

#### Order for spare parts

Order according to the order number or type label details of the manufacturer. Please contact the manufacturer.

## **Maintenance and repair**

## 9 Faults

In the case of faults that cannot be remedied by the following information, please contact the manufacturer, refer to the service address on page 2.

### 9.1 Safety

#### Electrical system



**DANGER!**

**Danger of death due to electrical current!**

refer to chapter .

#### Secure against switch-on



**WARNING!**

**Danger of death due to unauthorised switch-on!**

refer to  Chapter 2.8.1 “Securing against switch-on” on page 15.

#### Poisonous mediums



**WARNING!**

**Danger of damages to health due to residues of poisonous mediums in the fan casing!**

- Before working on the interior, make sure that no poisonous residues of mediums are inside the fan.

#### Moving components



**WARNING!**

**Risk of injury due to moving components!**

Refer to chapter .

## Faults

### Incorrectly implemented work to address faults



#### **WARNING!**

#### **Danger of injury due to incorrectly implemented work to address faults!**

- Ensure that there is sufficient space for assembly before beginning any work.
- Pay attention to tidiness and cleanliness in the place of assembly! Loosely positioned components or those left lying around are potential sources of accidents.
- When components have been removed, pay attention to correct assembly, reinstall all fixing elements and comply with the screw torque levels.
- Pay attention to the following before initialisation:
  - Ensure, that all maintenance work has been implemented and completed in accordance with the details and information in the manual.
  - Ensure that no persons are within the danger area.
  - Ensure that all covers and safety equipment is installed and in perfect working order.

### Conduct in case of faults

The following generally applies:

- 1.** ▶ Initiate the emergency stop in case of faults that represent a direct danger to persons or valuables. Refer to chapter 7.3 "Stoppage in case of an emergency" .
- 2.** ▶ Determine the cause of the fault.
- 3.** ▶ If addressing faults requires work within the danger area, switch the machine off and secure it against being switched back on. Inform the responsible person on-site immediately about the fault.
- 4.** ▶ Depending on the type of fault, arrange for it to be addressed by authorised personnel or address it yourself.

### Faults displays



*The display of faults takes place through the control system to be provided by the operator.*

*Further information on the fault displays can be taken from the documentation belonging to the control system.*



**9.2 Faults table**

<b>Fault</b>	<b>Possible cause</b>	<b>Remedy</b>
<b>Fan/motor is not running</b>	No voltage	- Check the supply of electricity - Reproduce the supply of electricity
<b>Motor protection has switched off</b>	Fuse is defective	- Check the fuse - Insert a new fuse - Check the motor protection
	Impeller won't move	- Contact the manufacturer
	Bearing damages	- Contact the manufacturer
<b>Grinding noises</b>	Impeller is grinding	- Switch off the fan! - Contact the manufacturer
<b>heavy vibrations</b>	Imbalance	- Switch off the fan! - Contact the manufacturer
	Resonance vibrations in frequency converter operat.	- Phase out the resonance frequency on the frequency converter
<b>Bearing noises</b>	Bearing damage	- Keep the fan under control! - Contact the manufacturer
<b>Pressure/volume current reducing</b>	System parts are not functional e.g. filter, flap	- Perform functional test on system parts - Contact the manufacturer

## **Faults**

### 10 Disassembly and disposal

After the end of service, the machine has to be dismantled and disposed of in an environmentally-friendly manner.

#### 10.1 Safety

##### Electrical system



**DANGER!**

**Danger of death due to electrical current!**

refer to chapter .

##### Incorrect dismantling



**WARNING!**

**Danger of injury due to incorrect dismantling!**

- Ensure that there is sufficient space for assembly before beginning any work and handle open, sharp edged components with care.
- Pay attention to tidiness and cleanliness at the place of assembly! Loosely positioned components or those left lying around are potential sources of accidents.
- Mount the components professionally. Pay attention to the heavy weight of the actual component. Use lifting equipment if necessary.
- Secure components so that they cannot fall down or fall over.
- Contact the manufacturer in case of any uncertainty.

#### 10.2 Dismantling and disposal

Prerequisites:

- Switch the machine off and secure it against being switched back on.
- Physically disconnect the full energy supply from the machine and discharge the stored residual energy. Remove any materials and aids as well as any residual processing materials and dispose of them in an environmentally-friendly manner.

To finish, professionally clean modules and components and dismantle under compliance with the valid local work safety and environmental protection regulations.

## **Disassembly and disposal**

## 11 Appendix

### Tightening torque values for screws

When tightening screws, adhere to the following tightening torque values based on VDI 2230 Oct. 2001.

	Hex. screw	Hex. screw	Hex. screw	Hex. lock nut
Standard screw	DIN EN ISO 4014 / 4017	DIN EN ISO 4014 / 4017	DIN EN ISO 4014 / 4017	
Standard nut	EN ISO 4032	EN ISO 4032	EN ISO 4032	EN ISO 4032
Strength category	8.8	10.9	A70	8.8
M5 [Nm]	8	-	5.1	-
M6 [Nm]	10	-	9	-
M8 [Nm]	25	36	22	25
M10 [Nm]	49	72	44	49
M12 [Nm]	85	125	74	85
M16 [Nm]	210	310	183	210
M20 [Nm]	425	610	370	425
M24 [Nm]	730	1050	608	730

## Appendix